



Summary

- C.3** General characteristics
- C.4** Fixed circuit breaker
- C.5** Withdrawable circuit breakers
- C.6** Characteristics
- C.7** RV23: protection and control unit
- C.9** Auxiliaries
- C.13** Order Codes
- C.17** Overall dimensions
- C.20** Weights
- C.21** RV and wiring diagram

Notes

Circuit Breakers 400 to 2500A - Series SP

Rated short-circuit breaking capacity: Ics 50 to 55kA (415V)

Complete range

- Fixed or withdrawable versions
- 3 or 4 poles
- Electrical or manual control

The SPECTRONIC range combines the legendary reliability of our air circuit breakers with:

- A design adapted to the new panel boards
- Protection relay: RV 23

Main advantages

- Clever design combining longevity and reliability
- Maximum service: total selectivity is ensured, even at closing on short circuit
- Simple and efficient servicing on site
- Safety ensured by fully visible breaking.

Conformity

The circuit breakers SP are built according to the following standards: IEC 947-2, BS, CEI, NBN, NFC and VDE.

Certification: Bureau Véritas, Lloyd's Register of Shipping, ASEFA.

Certification: Germanischer Lloyd (in accordance with IEC 157.1)

Tropicalisation

- Class I (standard): Relative humidity of 80% at 40°C (Hot and dry or damp climate of temperature zones).
- Class II: Relative humidity of 95% at 45°C (hot and damp climate).

Anti-corrosion treatment

For special atmospheres, consult us.



Rated short-circuit breaking capacity

following IEC 947-2 (415V)

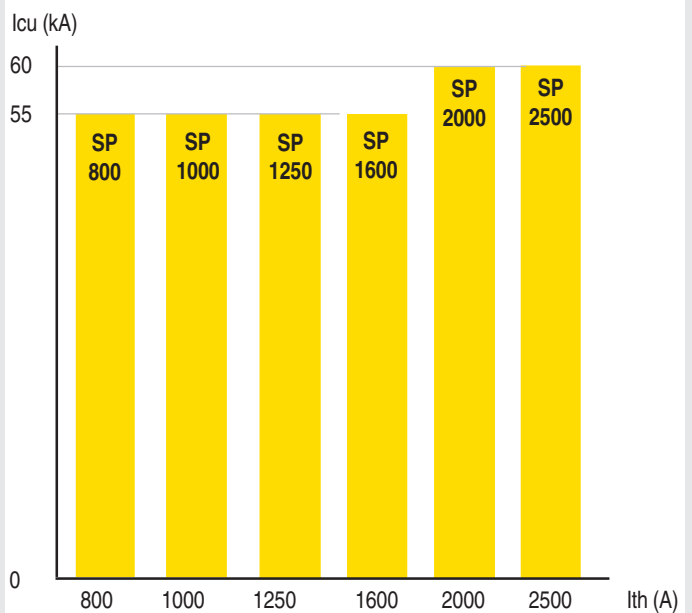

Fixed circuit breaker

C
4



Description

Fitted at the factory with a control panel providing an IP30 degree of protection. For panel mounting, a seal and a cover permit IP3X protection with the door closed.

Installation

- Fixed to vertical uprights or on horizontal surface.
- Main connections (see table page D.27).
- Connections to auxiliary circuits by terminals located at the front of the unit (max 24 terminals).
- Supplied with 12 terminals as standard, mounted on the right.

Power supply orientation

Up to 415V, connections are made either to the upper or lower terminal clamps. Above 415V, connect to the upper terminals.

- ① Local trip and reset push button (BPD).
- ② Circuit breaker position indicator. Red = closed - Green = open.
- ③ Trip lever prior to withdrawal or plugged-in operations.
- ④ Auxiliary switches.
- ⑤ RV 03 or RV 23 releases.
- ⑥ Volmetric releases: shunt and undervoltage releases.
- ⑦ Locking in "connected" position or locking in "withdrawn" position.
- ⑧ Fixed auxiliary terminal block.
- ⑨ Electrical control.
- ⑩ Current transformer.
- ⑪ Position contact 'withdrawn-inserted'.
- ⑫ EX trip actuator.
- ⑬ Digital ammeter (optional).
- ⑭ Distinct fault signalling (optional).
- ⑮ Arc chute.
- ⑯ Isolating shutter.
- ⑰ Reinforced ground plug.
- ⑱ Primary jaw.
- ⑲ Fault contact.

Withdrawable circuit breaker

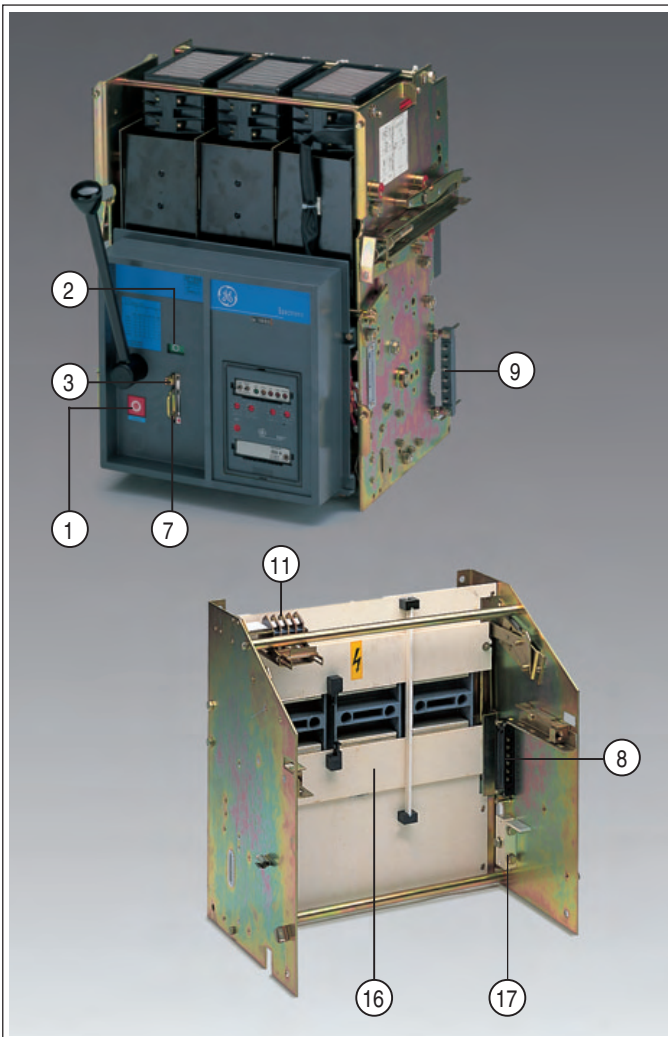
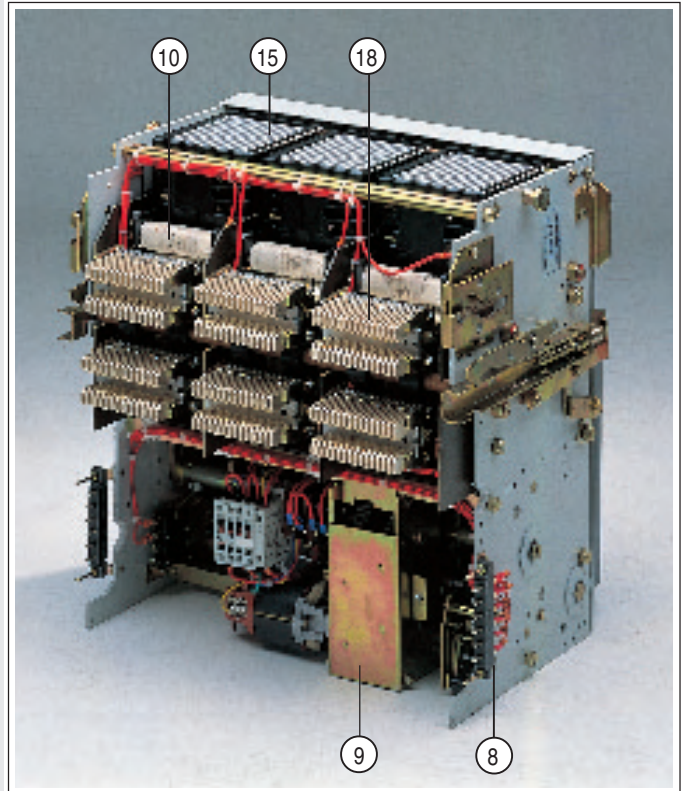

Description

The circuit breaker is mounted on a cradle fitted with slides allowing two positions: "inserted" and "withdrawn-isolated".

The insertion and withdrawal operations are performed by a screw-nut system, operated by two removable cranks.

Automatic tripping of the breaker on withdrawal is ensured by a safety device at the insertion of the cranks.

For panel mounting, a seal and a cover, permit IP3x protection with the door closed.

The circuit breaker may be withdrawn either with the door closed or open.

Installation

- Fixing to the vertical uprights by rear surface or on a horizontal surface by adding L pieces on side faces.
- Main connections (see table on page D.27).
- The auxiliary circuits disconnect automatically and simultaneously with the main circuit.
- Connections to the auxiliary circuits are made laterally with clips(maximum 24 terminals)
- Standard unit equipped with 12 terminals.

Power supply orientation

Up to 415V, connections are made either to the upper or lower terminal clamps. Above 415V, connect to the upper terminals.

Characteristics

Circuit Breakers

		SP 800	SP 1000	SP 1250	SP 1600	SP 2000	SP 2500
Rated insulation voltage U_i	(V)	1000	1000	1000	1000	1000	1000
Rated impulse voltage U_{imp}	(kV)	8	8	8	8	8	8
Rated maximum nominal voltage U_e	(V)	690	690	690	690	690	690
Rated thermal current I_{th}	40°C (A)	800	1000	1250	1600	2000	2500
	50°C (A)	800	1000	1250	1600	2000	2500
	60°C (A)	800	1000	1250	1500	1900	2350
Rated ultimate short-circuit breaking capacity I_{cu}							
Alternating current 50/60Hz	240/415V (kA)	55	55	55	55	60	60
	500V (kA)	35	35	35	35	35	35
	690V ⁽¹⁾ (kA)	40	40	40	40	40	40
Rated service short-circuit breaking capacity I_{cs}							
Alternating current 50/60Hz	240/415V (kA)	50	50	50	50	55	55
	500V (kA)	35	35	35	35	35	35
	690V ⁽¹⁾ (kA)	40	40	40	40	40	40
Rated peak short-circuit making capacity (max) I_{cm}	(kA peak)	120	120	120	120	130	130
Rated short time withstand current I_{cw} : 1 sec.							
415V (kA eff.)		50	50	50	50	55	55
	500V (kA eff.)	35	35	35	35	35	35
Utilization category		B	B	B	B	B	B
Number of poles		3-4	3-4	3-4	3-4	3-4	3-4
Suitable for isolation (visible breaking indication)		•	•	•	•	•	•
Endurance (number of operating cycles)							
Mechanical (total)	# operating cycles	10000	10000	10000	10000	10000	10000
Electrical (at 415V) ⁽²⁾	# operating cycles	10000	10000	10000	10000	5000	3500
Mean time between maintenances	# operating cycles	1500	1500	1500	1500	1500	1500
Power dissipation (withdrawable, 3 poles)	(W)	150	200	300	400	450	500
4th pole conventional thermal current	(A)	800	1000	1250	1600	1250 ⁽³⁾	1250 ⁽³⁾
Pollution degree		3	3	3	3	3	3
Dimensions in mm (fixed version)							
3 poles	Height (mm)	462	462	462	462	462	462
	Width (mm)	370	370	370	370	464	464
	Depth (mm)	273.5	273.5	273.5	273.5	273.5	273.5
4 poles	Height (mm)	462	462	462	462	462	462
	Width (mm)	458	458	458	458	52	562
	Depth (mm)	273.5	273.5	273.5	273.5	273.5	273.5

(1) On request.

(3) Neutral reduced to the left.

(2) To guarantee this number of operations, it is necessary to check the spark arrestors and the arc chutes as shown in the table above (Replace them when necessary)
This can be done easily on site

Switches

		SP 800	SP 1000	SP 1250	SP 1600	SP 2000	SP 2500
Rated thermal current at 40°C I_{th}	(A)	800	1000	1250	1600	2000	2500
Rated peak short-circuit making current I_{cm}	(kA peak)	120	120	120	120	130	130
Rated short time withstand current I_{cw} : 1 sec.							
415V (kA eff.)		50	50	50	50	55	55
	500V (kA eff.)	35	35	35	35	35	35
Dimensions in mm (fixed circuit breaker): See circuit breaker table above							

RV 23: Protection unit for SP400 to SP2500



Description

The RV 23 unit meets the requirements of the IEC 947.2 standard. This unit is powered by the current transformers and performs all the necessary three or four pole overcurrent protections.

The RV 23 is designed for :

- 3 pole or 4 pole protection: 3P/3P+N
- 3 pole with half neutral protection: 3P+N50%
- 3 pole or 4 pole ground fault protection

Note

In RV03 unit there are no LT delay setting and GF protection

Standard protection

- Overload protection (LT)
- Short-circuit protection (ST-I)
- Ground fault protection (GF)

Setting ranges

		Setting points
LT	(x In)	0.4 - 0.5 - 0.6 - 0.7 - 0.8 - 0.9 - 1
LTD	(s)	5 - 15 - 40 delay at 6 Ir
ST	(x In)	2 - 3 - 4 - 6 - 8 - 10
Time delay	(ms)	50 - 100 - 200 - 300 - 500
I	(x In)	2 - 3 - 5 - 8 - 10 - OFF
GF	(x In)	0.25 - 0.3 - 0.4 - 0.5 - 0.6 - 0.7
Time delay	(ms)	200 - 300 - 400

$$I_r = k \times I_n$$

Front face options

The RV unit may supplied with following modules.

Optional distinct fault signalling (LT, ST-I, GF)

This option displays locally by LED and dry contacts the origin of the fault.

Optional Load monitoring

threshold setting : (0.5 - 0.6 - 0.7 - 0.8 - 0.9 - 10) x Ir

Optional Ammeter

A digital ammeter permanently displays the maximum current value.

The current of other phases is available locally.

Internal Options

Auxiliary power supply

24V DC - 15W or 24V AC - 15 VA RV front face options

RV 23: Protection unit for SP400 to SP2500

Setting and operating current values

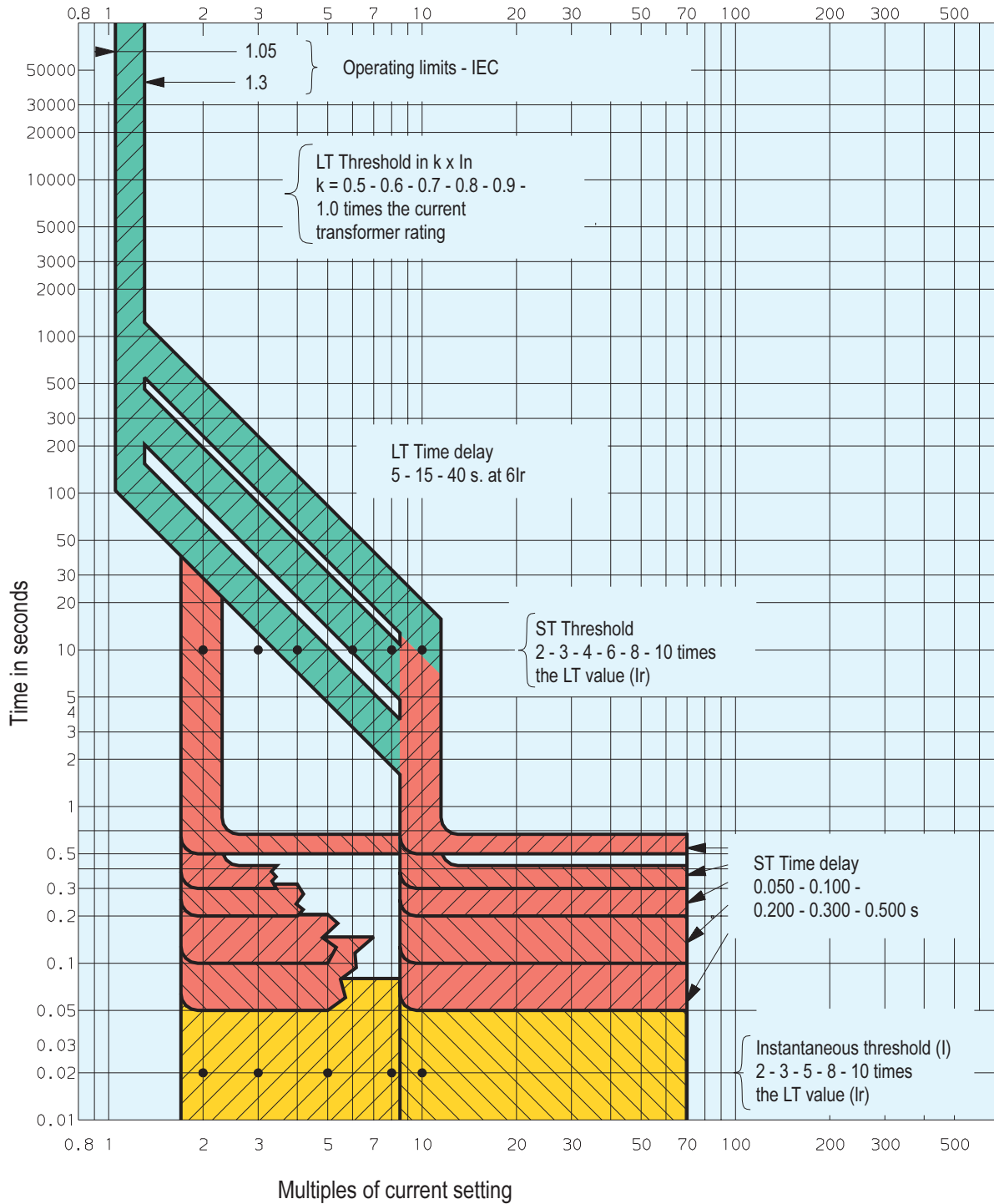

Electrical control



The electrical control is integrated within the overall dimensions of the circuit breaker. An easy adaption can be made to manual control.

- Breaker mechanism driven by a device with a universal motor.
- Automatic disconnection of the motor at the end of the operation.
- "Making" via a relay.
- Tripping by shunt trip or undervoltage release.
- Manual emergency control.
- Automatic reset.
- Manual reset after tripping due to fault.

Note

In case of continuous signal to close, interrupt this signal during 0.3 sec minimum, to allow electrical control to reset properly.

Characteristics

Rated service voltage U_n	
Alternating current 50Hz	V
Alternating current 60Hz	V
Direct current	V
Operating voltage	
Operating time at making	ms
Power consumption	
Breaker type	
Alternating current	VA
Direct current	W

48-110-127-220-240-380	
48-110-220-240-380	
48-60-110-220V	
from 0.85 to 1.1 U_n	
150 at U_n	
SP800 to1600 SP2000 and 2500	
1600	2000
800	1000

Electrical control 48V: section of the supply cables to be specified in accordance with the distance from the supply

Section (mm ²)	Distance from supply (m)
2.5	4
4	7,5
6	11
10	21

Voltmetric releases

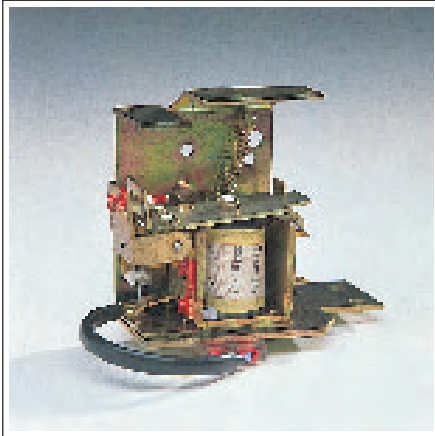

Characteristics

Rated voltage U_n		
Alternating current 50Hz	(V)	
Alternating current 60Hz	(V)	
Direct current	(V)	
Operating voltage		
Power Consumption		
Alternating current	closing (VA) holding (VA)	
Direct current	≤ 220V (W) 440-500V (W)	
Circuit breaker open time		(ms)

Maximum equipment

1st possibility	
2nd possibility	
3rd possibility	

Two types of releases enable the remote controlled operation of the circuit breaker.

SHUNT TRIP RELEASE EA-EA1-EB

Actuates the breaking of the circuit breaker (the power supply is cut by an auxiliary contact).

UNDERVOLTAGE RELEASE UVR-UVRD

Actuates the breaking of the circuit breaker when the power supply voltage falls to a value between 35 and 70% of its rated value.

UVR: Instantaneous action.

UVRD: action delayed by 250 ms or 0.6 s, alternating current power supply.

Other delaying devices available upon request.

Shunt trip			Undervoltage release
EA	EA1	EB	UVR
24-48-110/127-220-380/500	127-220-380/415-500	24-48-110/127-220-380/415-500	24-48-110/127-220-380-415-500
24-48-110/127-220-380/500	-	220-380	24-48-110/127-220-380
24-48-110/120-220/500	-	24-48-110/120-220	24-48-110-120-220-440-500
from 0.7 to 1.1 U_n	from 0.1 to 1.3 U_n	from 0.7 to 1.1 U_n	from 0.35 to 0.7 U_n ⁽¹⁾
80 to 100	800	450	23
-	-	-	10
30	-	180 (660 for 48V)	6
275	-	-	21
60	60	60	85
•	-	•	-
-	•	•	-
-	-	•	• ⁽²⁾

(1) Circuit breaker "making" ensured from 0.85 U_n .

(2) or UVRD

Auxiliary switches AS - SAS

Actuated at the same time as the main poles, the auxiliary contacts indicate the open or closed position of the circuit breaker.

Mounting possibilities:

- Either 6 AS changeover switches
- or 3 SAS special changeover switches for DC applications (it is not possible to combine AS and SAS).

For low voltage contacts, 4 to 30V - 1 to 100mA, consult the sales office.

C
11

Characteristics

Thermal current I _{th}	(A)
Interrupting capacity	
Alternating current cos φ 0.3	
48V	(A eff.)
127V	(A eff.)
220V	(A eff.)
380V	(A eff.)
Direct current L/R 0.01s	
48V	(A)
120V	(A)
220V	(A)

AS	SAS
20	17.5
12	-
12	-
12	-
5	-
3	10
0.7	8
0.45	5

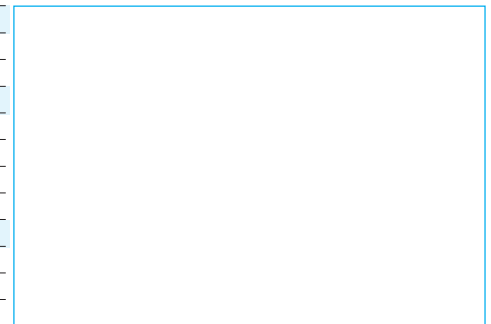
Fault contact (Bell alarm) BA

Common fault signals for overload and short-circuit.

Possibility of two changeover switches BA1, BA2 activated by RMS 7 or RMS 9.

After release it is necessary to reset the contacts by pushing the local mechanical push button situated on the control panel (BPD).

Characteristics

Thermal current I _{th}	(A)
Interrupting capacity	
Alternating current cos φ 0.3	
48V	(A eff.)
127V	(A eff.)
220V	(A eff.)
380V	(A eff.)
Direct current L/R 0.01s	
48V	(A)
120V	(A)
220V	(A)

BA	
20	
12	
12	
12	
5	
3	
0.7	
0.45	

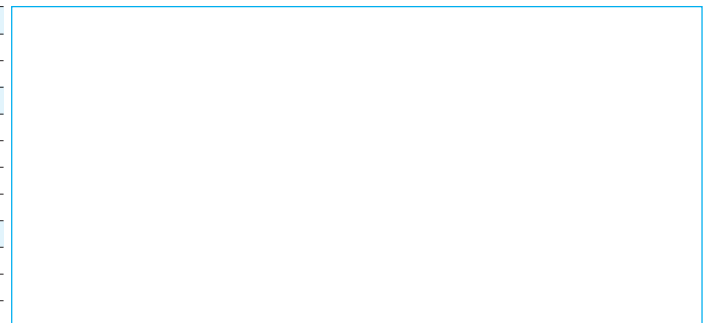

Position contacts for withdrawable circuit breakers



Safety contact in “connected” position CAE 12

Indicates that the closing of the breaker can be actuated; the breaker is in “Connected” position, operating cranks not inserted.

Possibility of a changeover switch.

Connection by clips of 6.35 mm.

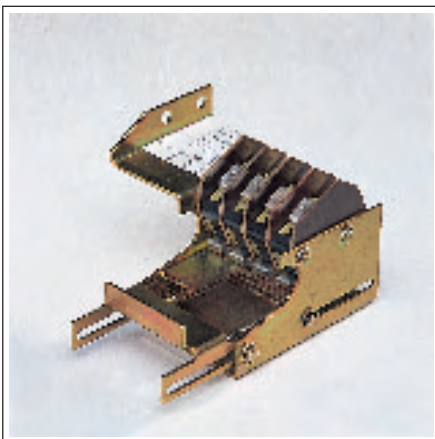

“Connected” position contact CAE

Indicates the position of the circuit breaker in its cradle.

Possibility of 2 changeover switches CAE 51, CAE 52.

Connection by clips of 6.35 mm.

Withdrawn position contact CAD

Indicates the position of the circuit breaker in its cradle.

Possibility of 2 changeover switches CAD 61, CAD 62.

Connection by clips of 6.5 mm.

Characteristics

Thermal current I _{th}	(A)	20
Interrupting capacity		
Alternating current cos φ 0.3		
48V	(A eff.)	12
127V	(A eff.)	12
220V	(A eff.)	12
380V	(A eff.)	5
Direct current L/R 0.01s		
48V	(A)	3
120V	(A)	0.7
220V	(A)	0.45

Equipment for withdrawable circuit breakers

Auxiliary secondary disconnect system

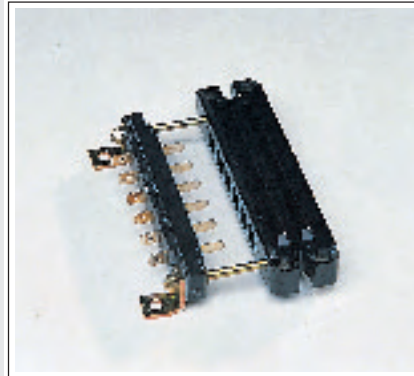

Includes a fixed part (female sockets) mounted on the cradle and a moving part (male sockets) mounted on the circuit breaker

- Device permits connection of 6 circuits of 10 A per block.
- Mounting of 4 devices maximum.

Isolating shutter

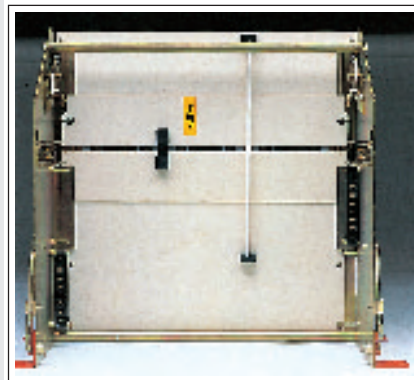

Prevents access to energised parts when the circuit breaker is in “withdrawn” position.

Provided with a padlocking system (padlock not provided).

Test position cord

Use in place of secondary disconnects.

Possibility of equipping the circuit breaker with a connector for testing the auxiliaries in the “disconnected” position.

Reinforced ground plug

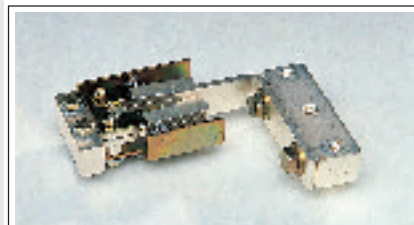

Reinforces the natural electrical continuity between the cradle mass and the circuit breaker (I_{cc} 25kA - 0.5 s).

Remove the lower right wire secondary disconnection block.

Circuit breakers
Without Protection

FIXED with rear horizontal terminals

Front terminal kit



WITHDRAWABLE Moving part

+

Fixed part cradle with front terminals

Cradle with rear horizontal terminals

Higher value for 690V version
RV protection unit

Current transformer

	SP 800	SP 1000	SP 1250	SP 1600	SP 2000	SP 2500
3P	756303	756313	756323	756333	756343	756353
4P	756304	756314	756324	756334	756344	756354
3P	756150	756150	756152	756152	756154	756154
4P	756151	756151	756153	756153	756155	756155

3P	756301	756311	756321	756331	756341	756351
4P	756302	756312	756322	756332	756342	756352

3P	756100	756100	756100	756100	756102	756102
4P	756101	756101	756101	756101	756103	756103

3P	756105	756105	756105	756105	756107	756107
4P	756106	756106	756106	756106	756108	756108

3P	756136	756136	756136	756136	756138	756138
4P	756137	756137	756137	756137	756139	756139

755363 RV 03

755365 RV 23

Rating A	SP 800	SP1000	SP 1250	SP 1600	SP 2000	SP 2500
400	756030	-	-	-	-	-
630	756031	-	-	-	-	-
800	756032	-	-	-	-	-
1000	-	756033	-	-	-	-
1250	-	-	756034	-	-	-
1600	-	-	-	756035	-	-

2000	-	-	-	-	756037	-
2500	-	-	-	-	-	756039

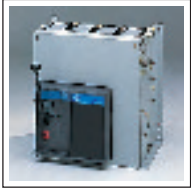
Switches

FIXED with rear horizontal terminals

Front terminals kit



WITHDRAWABLE
Moving part

+

Fixed part
cradle with front terminals

Cradle with rear horizontal terminals

Higher value for 690V version

	SP 800	SP 1000	SP 1250	SP 1600	SP 2000	SP 2500	
3P	756403	756413	756423	756433	756443	756453	
4P	756404	756414	756424	756434	756444	756454	
3P	756150	756150	756152	756152	756154	756154	
4P	756151	756151	756153	756153	756155	756155	
3P	756401	756411	756421	756431	756441	756451	
4P	756402	756412	756422	756432	756442	756452	
3P	756100	756100	756100	756100	756102	756102	
4P	756101	756101	756101	756101	756103	756103	
3P	756105	756105	756105	756105	756107	756107	
4P	756106	756106	756106	756106	756108	756108	
3P	756136	756136	756136	756136	756138	756138	
4P	756137	756137	756137	756137	756139	756139	

Electrical auxiliaries

Electrical control

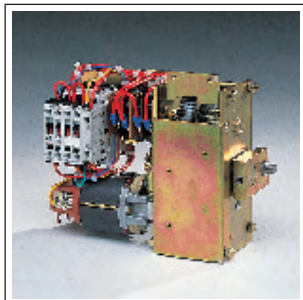

Use 4 connection terminals or secondary disconnections

SP

AC 50Hz

756200	48V
756201	110V
756224	127V
756233	220V
756231	240V
756205	380V

AC 60Hz

756206	48V
756201	110V
756233	220V
756225	240V
756211	380V

DC

756212	48V
756228	60V
756213	110V
756215	220V

Shunt trip release

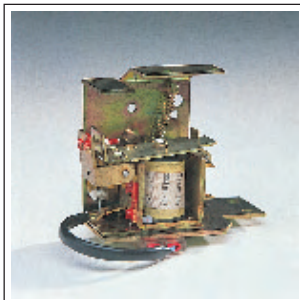

Use 2 connection terminals or secondary disconnections

EA

AC 50-60Hz

752200	24V
752201	48V
752202	110/127V
752203	220V
752204	380/500V

DC

752240	24V
752241	48V
752242	110/120V
752243	220/500V

EA1

AC 50Hz

752205	127V
752206	220V
752207	380/415V
752208	500V

EB

AC 50Hz

752210	24V
752211	48V
752212	110/127V
752213	220V
752214	380/415V
752215	500V

AC 60Hz

752248	220V
752249	380V

DC

752244	24V
752245	48V
752246	110/120V
752247	220V

Undervoltage trip release

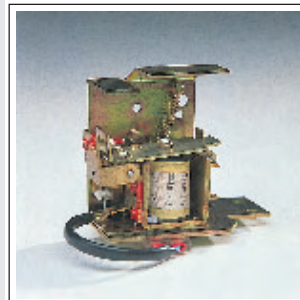

Use 2 connection terminals or secondary disconnections

UVR

AC 50Hz

752254	24V
752255	48V
752256	110/127V
752257	220V
752258	380V
752259	415V
752260	500V

AC 60Hz

752254	24V
752255	48V
752256	110/127V
752261	220V
752258	380/415V
752259	500V

DC

752288	24V
752289	48V
752290	110V
752291	120V
752292	220V
752293	440V
752294	500V

UVRD 250 ms

AC 50Hz

752216	220V
752217	380V

UVRD 0,6 s

AC 50Hz

752220	220V
752221	380V

Auxiliaries

Signalling contacts



NO	NC	NO/NC	
756061	756060	756062	AS 1
756064	756063	756065	AS 2
756067	756066	756068	AS 3
756070	756069	756071	AS 4
756073	756072	756074	AS 5
756076	756075	756077	AS 6
756081	756080	756082	SAS 1 ⁽¹⁾
756084	756083	756085	SAS 2 ⁽¹⁾
756087	756086	756088	SAS 3 ⁽¹⁾
752815	752816	752817	BA 1
-	-	752820	BA 2

⁽¹⁾ To fit 1, 2 or 3 SAS contacts, use adaption no. **756098**

Connection terminals or secondary disconnections to use:
 - by NO or NC contact: 2 terminals
 - by NO/NC contact switches: 3 terminals

Accessories

Secondary terminals

Fixed circuit breaker: block of 12 terminals (maximum 1 additional block).

756096 Left mounting

Withdrawable circuit breaker: block of 6 terminals (2 additional blocks maximum).

755907 Moving part

755908 Fixed part

755909 Fixed and moving part assembly

Isolating shutter

3P 4P

756110 **756111** SP 800-1600

756112 **756113** SP 2000 - 2500

Reinforced ground plug 25kA - 0.5 s

756132 For withdrawable circuit breaker

“Test” position cord

756127 Replace the secondary disconnection device

Circuit breaker contact positions in the cradle

756095 “Connected” position contact CAE, one changeover contact NO/NC

756094 “Withdrawn” position contact CAD, one changeover contact NO/NC

For each position two contacts are possible. Use an adaption no. **756095** for 2 CAE + 2 CAD
 Use 3 secondary terminals per contact.

“Connected cranks not inserted” contact CAE 12

752830 A changeover contact NO/NC
 Use 3 secondary disconnection terminals

Interlocking

Tripped position

753203 By Ronis lock (supplied)

753204 By lock (not supplied)

753205 By padlocks (not supplied)

Withdrawn position

753206 By Ronis lock (supplied)

753207 By lock (not supplied)

Source changeover mechanical interlock

Linkage permitting interlock:
 - 2 circuit breakers at 660 mm
 - 3 devices (on request)

756119 Fixed circuit breaker

756120 Withdrawable circuit breaker

Cable system permitting interlock between:

756141 2 fixed circuit breaker

756142 2 withdrawable circuit breaker

Operation counter



756133

Factory fitted

Door gasket

752818 Permits IP3x protection when panel mounted

Fixed circuit breaker

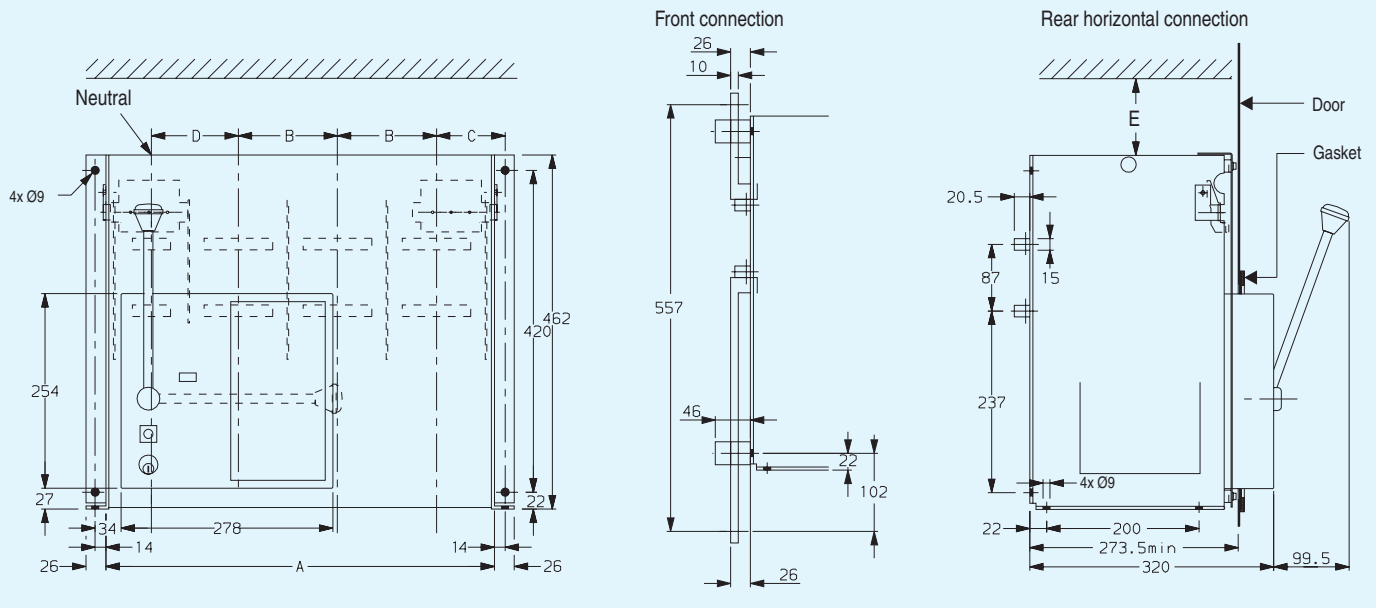

C
17

Panel cut out for fitting gasket

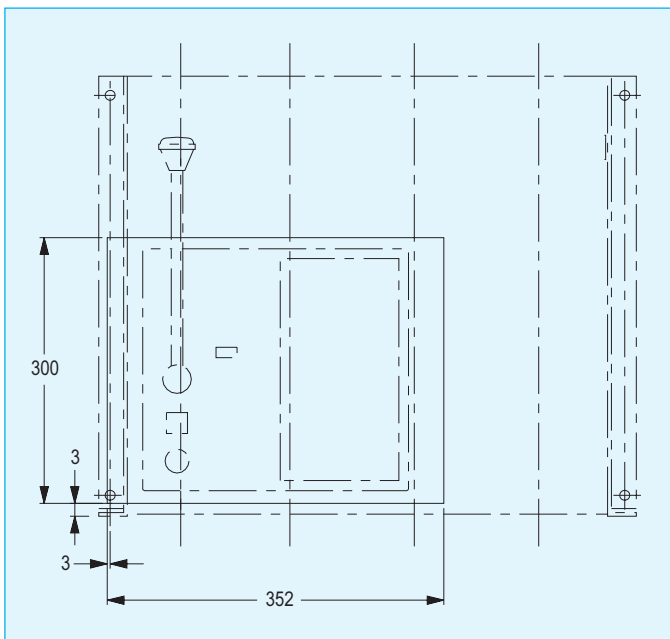

Rear horizontal connections

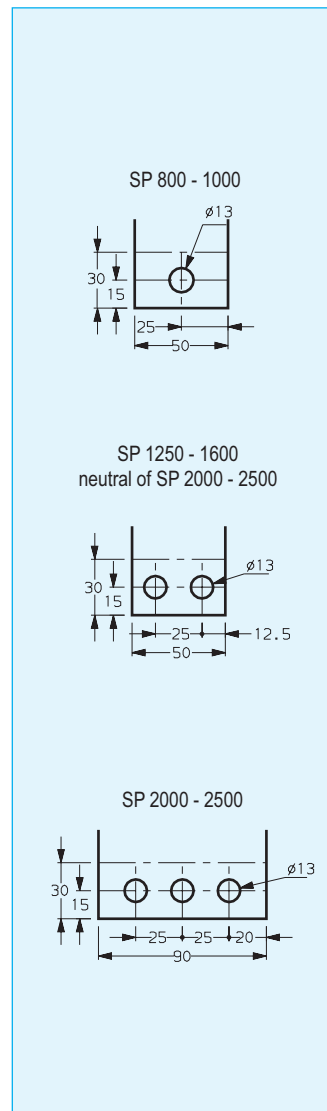

Front connections

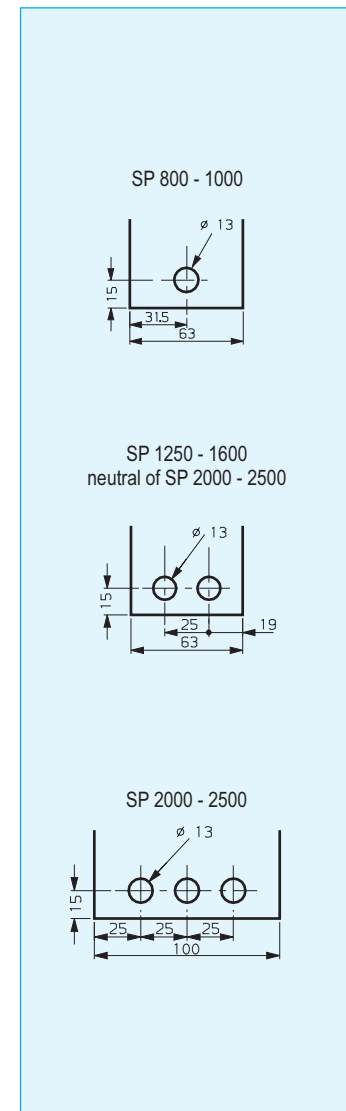

Legend

Type	Number of poles	A	B	C	D
SP 800 to 1600	3	318	98	75	-
SP 2000-2500	3	412	130	90	-
	4	510	130	90	114

E = minimum clearance distance above the arc chutes.

	Ue ≤ 500V	Ue ≤ 690V
I = Insulating screen	150 mm	150 mm
M = Metallic screen	150 mm	200 mm

Withdrawable circuit breaker

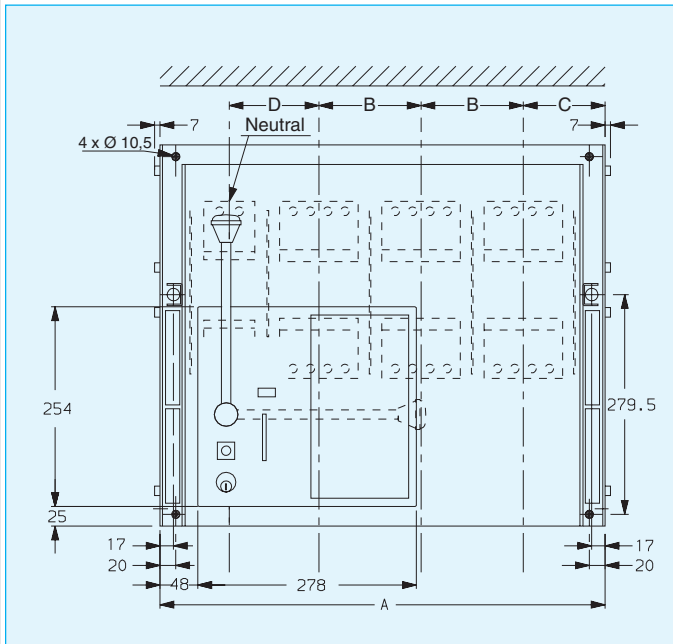

Front connection

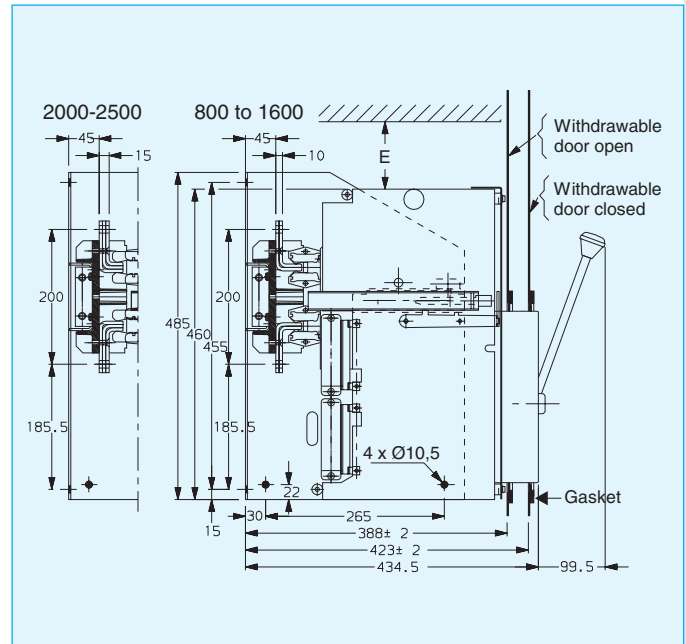

Panel cut out for gasket fitting

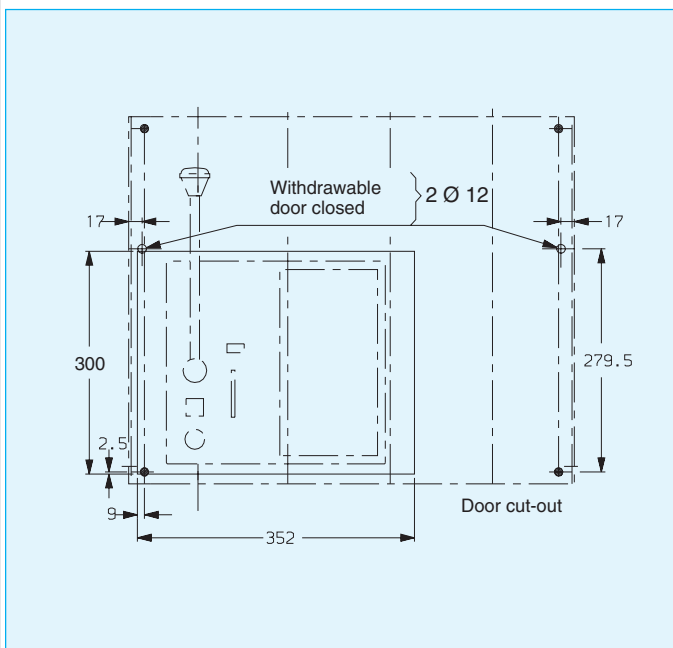

Rear horizontal connection

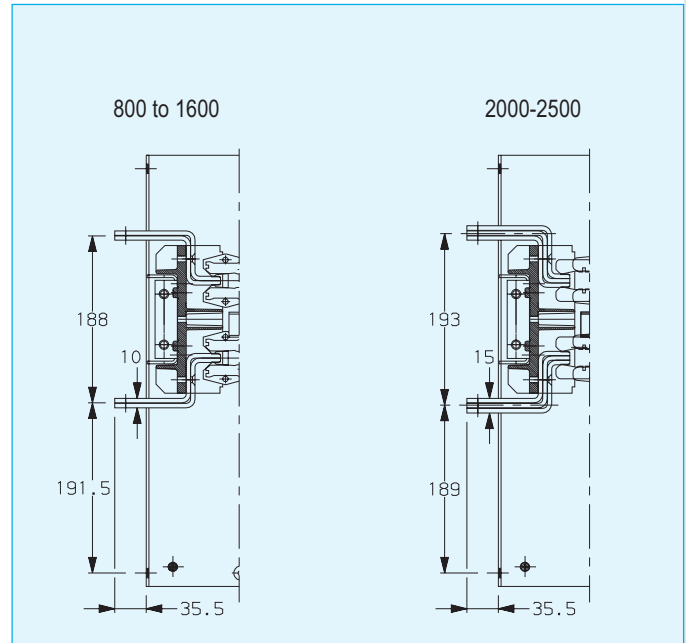

Legend

Type	Number of poles	A	B	C	D
SP 800 to 1600	3	374	98	89	-
SP 2000-2500	3	468	130	104	-
	4	566	130	104	114

E = minimum clearance distance above the arc chutes.

	Ue ≤ 500V	Ue ≤ 690V
I = Insulating screen	100 mm	100 mm
M = Metallic screen	150 mm	200 mm

Connection terminals

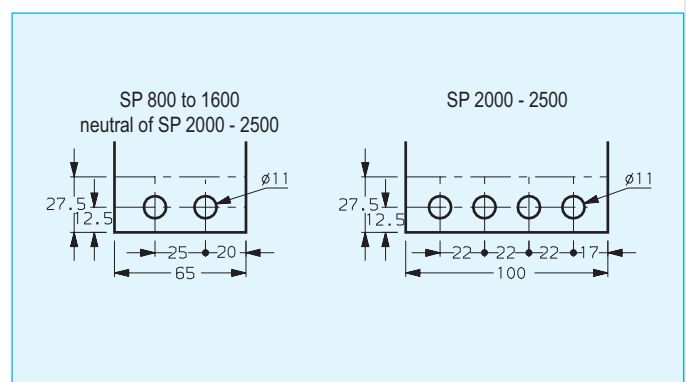

Source changeover switches IDS

Fixed circuit breakers without chassis

Type	Number of poles	A
SP 800 to 1600	3	334
SP 2000 - 2500	3	428
	4	526

White area: overall dimensions of interlocking system.

⊗ left alignment of circuit breaker fixation.

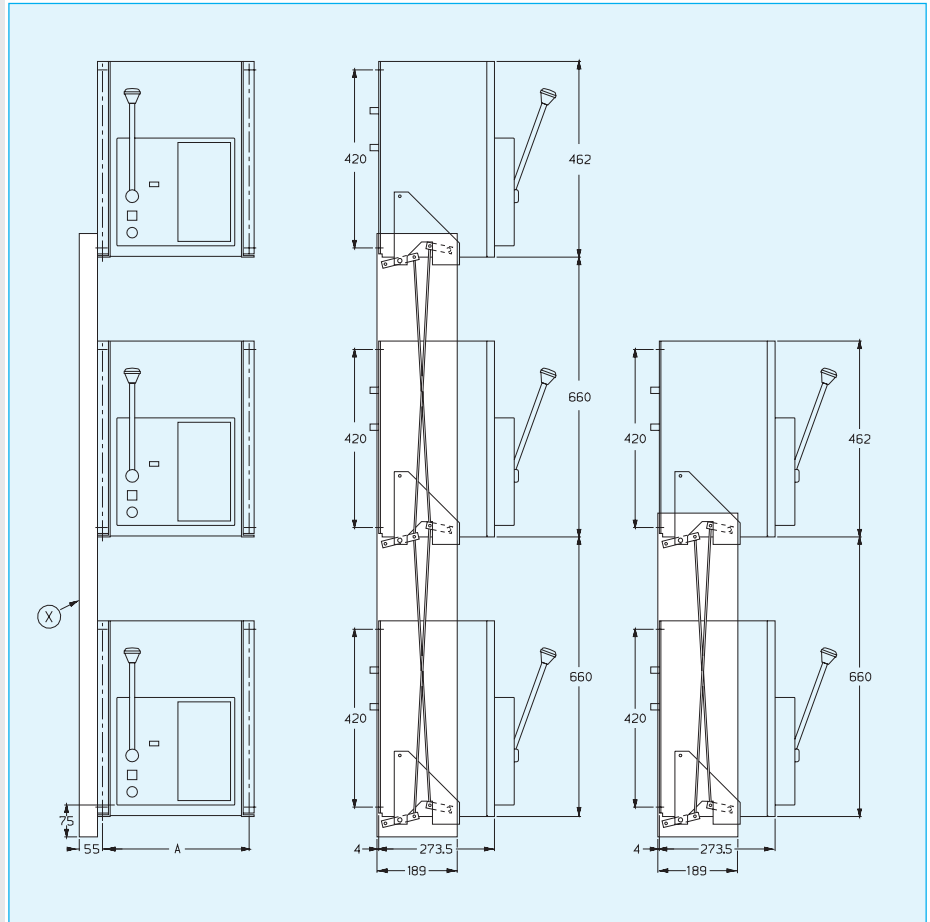

Withdrawable circuit breaker without chassis

Type	Number of poles	A
SP 800 to 1600	3	334
SP 2000 - 2500	3	428
	4	526

White area: overall dimensions of interlocking system.

⊗ left alignment of circuit breaker fixation.

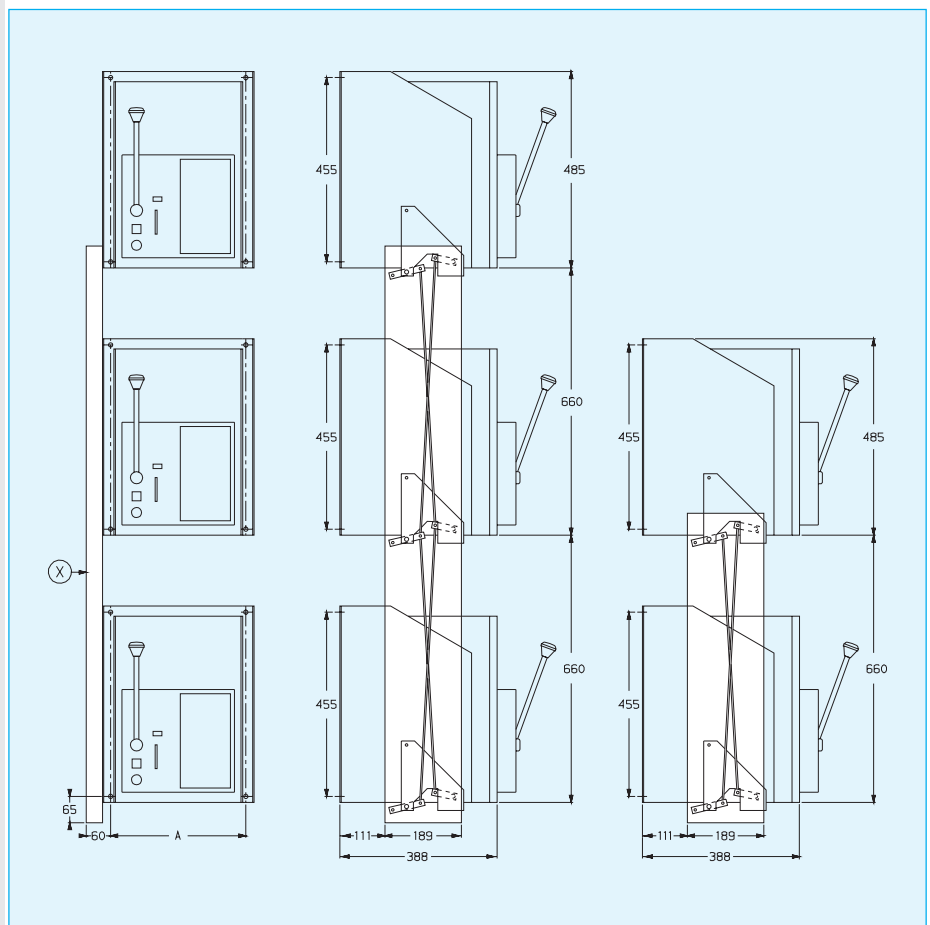

Connection possibilities

Fixed versions	SP
Rear horizontal terminals	X
Rear vertical terminals	O
Front terminals	X
Withdrawable versions	SP
Rear horizontal terminals	X
Rear vertical terminals	O
Front terminals	X

X = standard
O = on request

Weight of circuit breakers

(in kg)

		Fixed circuit breaker		Withdrawable circuit breaker	
		manual control	electrical control	manual control	electrical control
SP 400-800	3P	45	51	47	53
	4P	57	63	59	65
SP 1000	3P	45	51	47	53
	4P	57	63	59	65
SP 1250	3P	45	51	47	53
	4P	57	63	59	65
SP 1600	3P	45	51	48	54
	4P	57	63	60	66
SP 2000	3P	54	60	58	64
	4P	66	72	70	76
SP2500	3P	54	60	59	65
	4P	66	72	71	77

Weight of switches

(in kg)

		Fixed circuit breaker		Withdrawable circuit breaker	
		manual control	electrical control	manual control	electrical control
SP 400-800	3P	44	49	46	52
	4P	56	61	58	64
SP 1000	3P	44	49	46	52
	4P	56	61	58	64
SP 1250	3P	44	49	46	52
	4P	56	61	58	64
SP 1600	3P	44	49	47	53
	4P	56	61	59	65
SP 2000	3P	52	58	56	62
	4P	64	70	68	74
SP2500	3P	52	58	57	63
	4P	64	70	69	75

RV: Protection and measurement unit

Diagrams are shown without power supply, circuit breaker open, connected, reset and cranks not inserted.

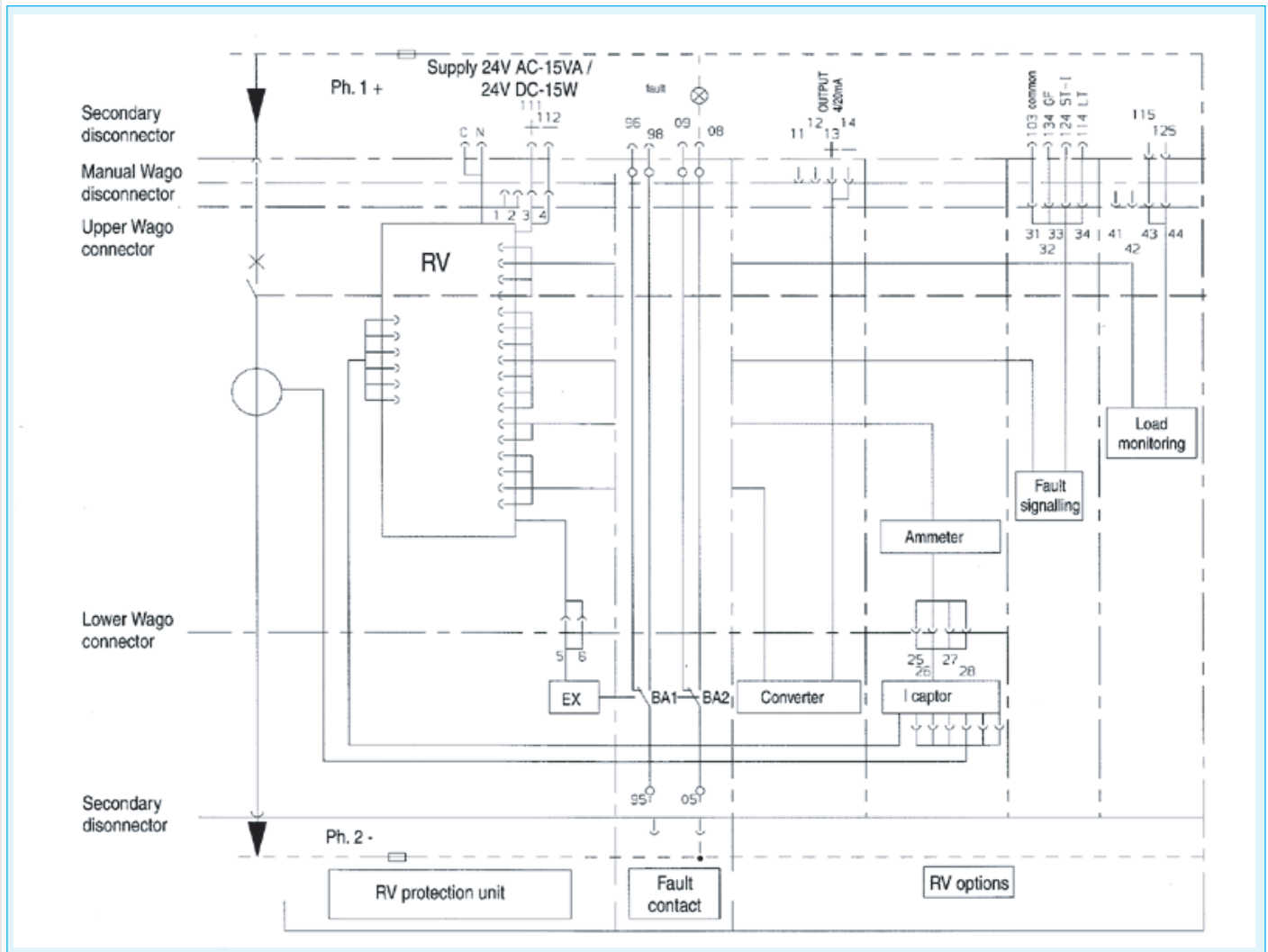

Legend

CAE 51 . 52	"connected" position contact
CAD 61 . 62	"withdrawn" position contact
CAE 12	"cranks not inserted" contact
BA1 - BA2	fault contact, overload and short-circuit with local reset after fault tripping
UVR	undervoltage release
UVRD	time delayed undervoltage release
RA	resistor for selected voltages in direct current
EA1 - EA - EB	shunt trip release
K	relay
FCE1 . 2	limit switch close
FCD	limited switch reset
M . m	motor
RH 50	resistor for 380V
C 21	interlock contact coupled with emergency control
AS - SAS	auxiliary switches
BPO	"Tripping" push-button
BPF	"Closing" push-button

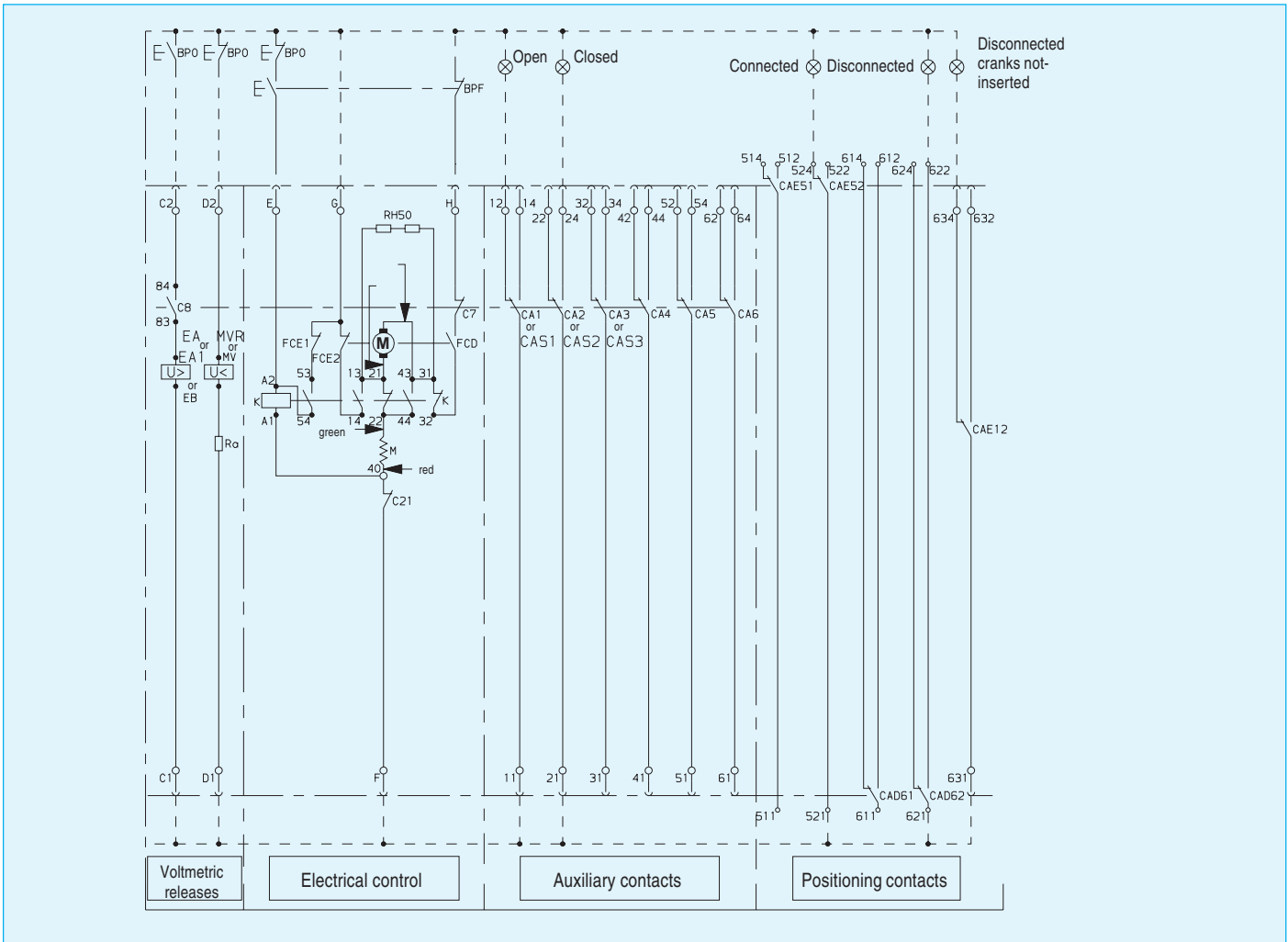

Electrical control

External wiring: wire cross section 2.5 mm² (for 48V power supply, the wire length is max. 20 m).
 For 48V: connection of electrical control on the circuit breaker and the C2 contact by 2.5 mm² wires.

End user connections

Fixed circuit breaker

Connection by terminals 6.3 x 0.8
 24 terminals maximum
 Letters in alphabetical order followed by increasing numbers

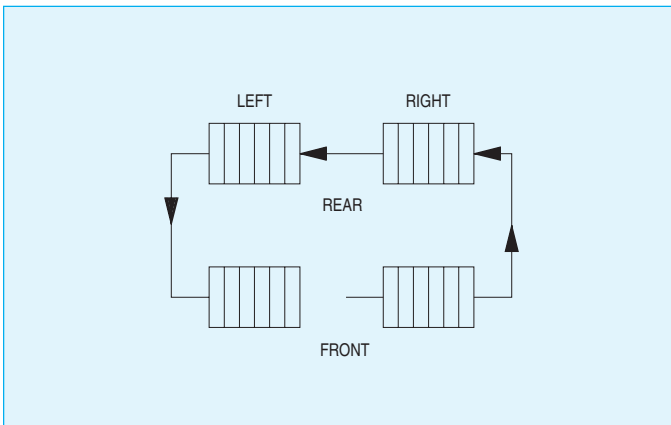

Auxiliary contacts

Six normal or three special auxiliary contacts.

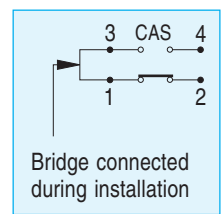

Withdrawable circuit breaker

Connections by terminals 6.3 x 0.8
 For the electrical control of EA1, EA, EB, CD1, CD2, MVR, MV, RMS 7, use the allocated terminals. Other accessories: numbers are increasing clockwise (use reserved terminals if they are available).

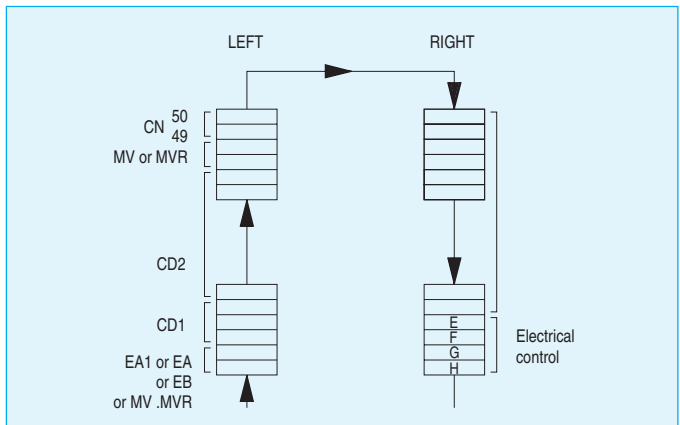

Notes

